

Product Name: **Incabin Boost Controller**  
Product Description: **Manual Boost Controller**  
Product Number: **TS-0106-1001**



#### ABOUT THIS PRODUCT

Thank you for purchasing your new Turbosmart Incabin boost controller (ICBC). This new model now has some great new features. These include:

- 2 ramp rates of boost to give you the option of a fast rise in boost or a slightly tame rise for more sensitive setups.
- A wider boost adjustment range for wastegates with low spring base pressures.
- A new mounting bracket to make it easier to mount.

#### IMPORTANT NOTES ON YOUR BOOST CONTROLLER

- Use only silicone hose that is the correct size and pressure rating for your application when fitting your boost controller – other hoses will be affected by heat and will eventually crack or split which could cause excessive boost pressure and engine damage
- Ensure that all plumbing is secured with clamps
- The ICBC connecting hose should be adequately shielded from heat and positioned at least 200mm from the turbine housing or the exhaust manifold
- A Turbosmart Fuel Cut Defender may need to be used in conjunction with your boost controller – refer to [www.turbosmart.com.au](http://www.turbosmart.com.au)
- **The boost dial has a left handed thread, be sure not to over tighten as this will damage the boost controller**

#### RECOMMENDATIONS

- **Turbosmart recommends that the Air Fuel ratio is checked once boost pressure is set**
- **Turbosmart recommends that boost pressure is set using a Dynamometer and not on the street**
- **Turbosmart recommends that a accurate boost gauge be permanently fitted to the vehicle**
- **Turbosmart recommends that your boost controller is fitted and adjusted by an appropriately qualified technician**

## HOW TO INSTALL YOUR BOOST CONTROLLER

#### TOOLS REQUIRED

General mechanic tools

#### 1) INTERNAL WASTEGATE SETUP

1. Allow the engine to cool down before installing your boost controller
2. Locate the pressure source port and the wastegate actuator port on the turbocharger assembly (refer drawing 1)
3. Remove the factory boost control solenoid if fitted from the boost pressure supply port while leaving the solenoid connected to the ECU
4. Install the tee piece in the wastegate pressure line with the wastegate arrow pointing towards the wastegate actuator and run the tee piece pressure line into the cabin and connect it to the bottom port of the boost controller
5. Run a second pressure hose line from the engine bay into the cabin and connect it to the top vent port
6. If your wastegate actuator has additional ports, these will need to be blocked
7. Secure all silicone hose ends with hose clamps
8. Mount your boost controller bracket inside the vehicle cabin, then attach the boost controller onto the bracket with the supplied screws
9. Make sure the boost dial is turned completely anti-clockwise before making adjustments.

Drawing 1

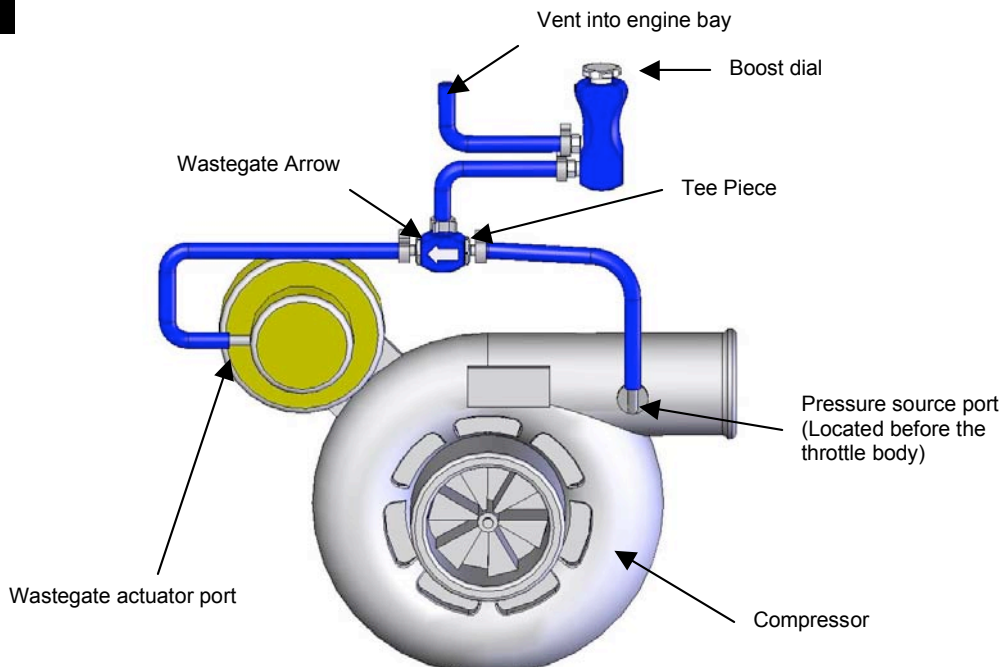

## HOW TO INSTALL YOUR BOOST CONTROLLER cont.

### 2) EXTERNAL WASTEGATE SETUP

1. Allow the engine to cool down before installing your boost controller
2. Locate the **bottom port** on the external wastegate and the pressure source port (refer Drawing 2)
3. Install the tee piece onto the bottom port of the wastegate as per the 4<sup>th</sup> step in the internal wastegate setup
4. Follow the 5<sup>th</sup> – 9<sup>th</sup> step of the internal wastegate setup

Drawing 2

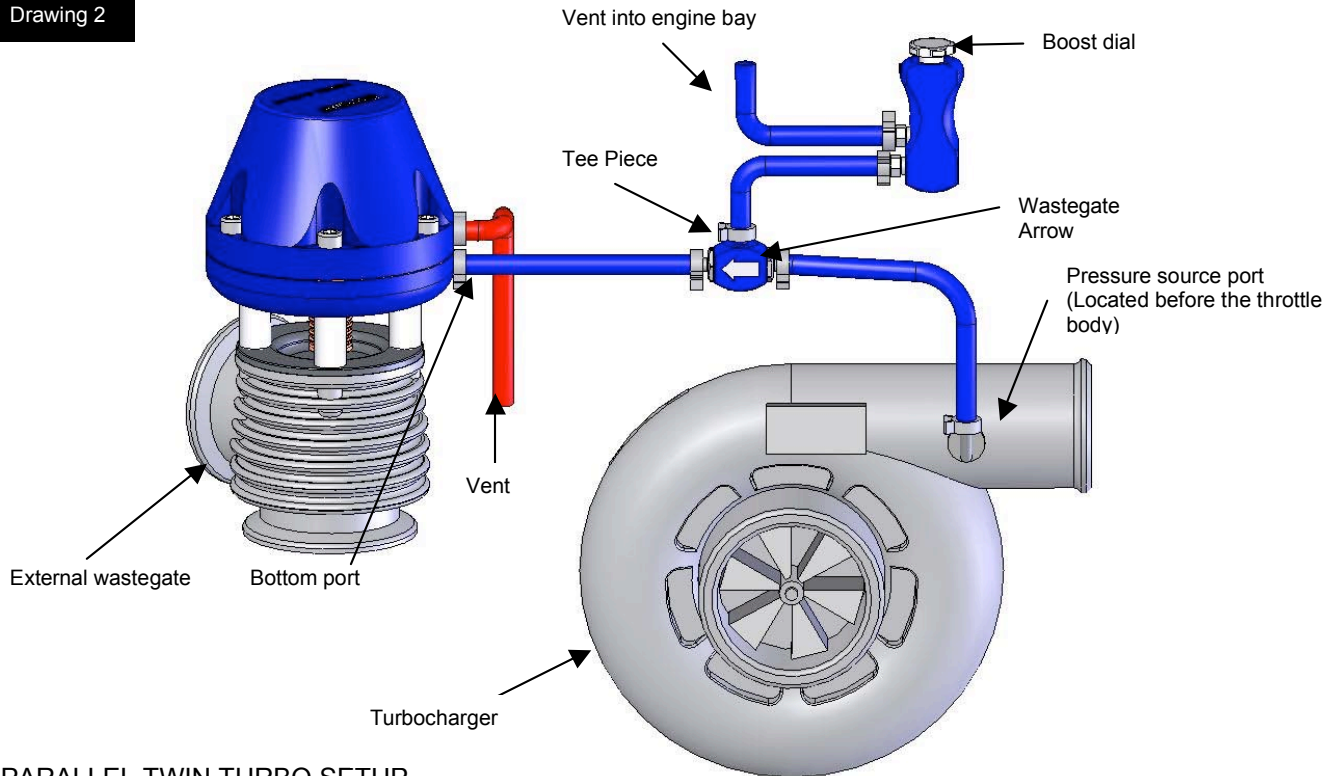

### 3) PARALLEL TWIN TURBO SETUP

1. Allow the engine to cool down before installing your boost controller
2. Locate the wastegate actuator ports on both turbochargers and a pressure source port (refer Drawing 3)
3. Remove the factory boost control solenoid if fitted from the boost pressure supply line
4. Install your boost controller tee piece in the wastegate pressure line with the wastegate arrow pointing towards the wastegate actuators as per step 4 in the internal wastegate setup instructions
5. Be sure to keep the hoses joining the wastegate actuators at equal lengths
6. Follow the 5<sup>th</sup> – 9<sup>th</sup> step of the internal wastegate setup

Drawing 3

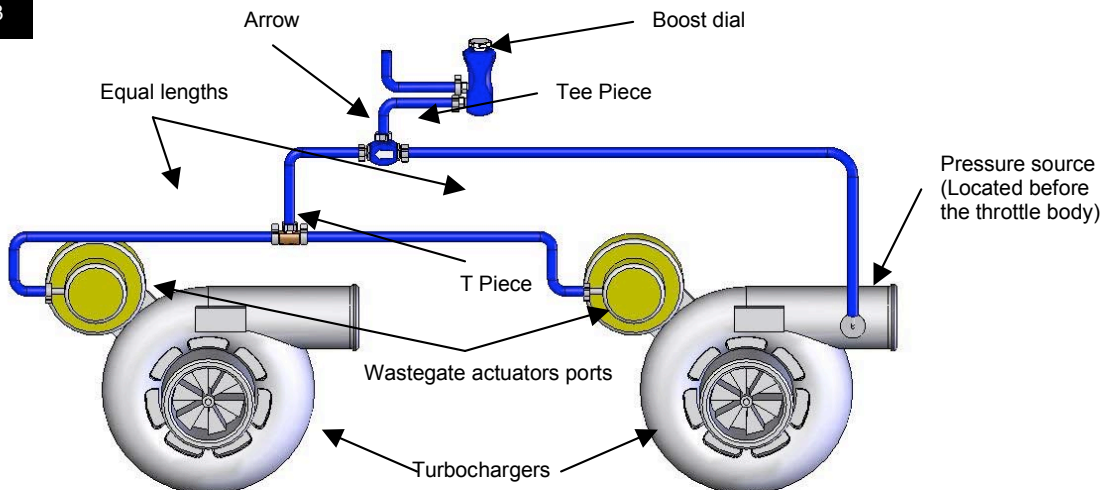

\*Note for sequential turbo systems: Sequential turbo setups can be complex and vary from car to car. Please contact your local Turbosmart dealer for more details

# SETTING BOOST PRESSURE

## IMPORTANT NOTES ON BOOST PRESSURE ADJUSTMENT

- Adjustment to your boost controller is made by rotating the **Boost Dial**
- Rotate in a clockwise direction to increase boost and the reverse direction to decrease boost
- Before making any adjustment, the **Boost Dial** will need to be fully closed (anti-clockwise)

**Step 1:** Apply full load to the engine in a high gear (at least 3<sup>rd</sup> or 4<sup>th</sup> gear) at full throttle and note the boost pressure

**Step 2:** To increase boost rotate the **Boost Dial clockwise** (maximum of 1 complete revolution at a time)

**Step 3:** Apply full load to the engine and note the boost pressure

**Step 4:** Compare the actual boost pressure with the desired boost pressure. If the actual pressure is below the desired pressure, return to step 2. If the actual is above the desired boost then decrease by rotating the **Boost Dial anti-clockwise** and return to step 3.

## BOOST SPIKING

If boost spiking occurs and is undesirable for your application, the gate system can be removed to give you a less aggressive boost curve. This modification is only required in a minimal number of applications.



## IMPORTANT NOTES ON GATE SYSTEM REMOVAL

The gate system can be removed by the following steps.

Perform this modification on a clean bench so that the ball and spring are not lost

- Allow the engine to cool down before removing the Tee piece from your vehicle
- Identify the input nipple with the restrictor at the end. Loosen the input nipple and remove the ball and spring.
- Check that the internal air passages are clear and free from debris
- Re-install the boost controller by following the instructions for your setup
- You will need to re-adjust your boost settings after the removal of the gate.

Drawing 4

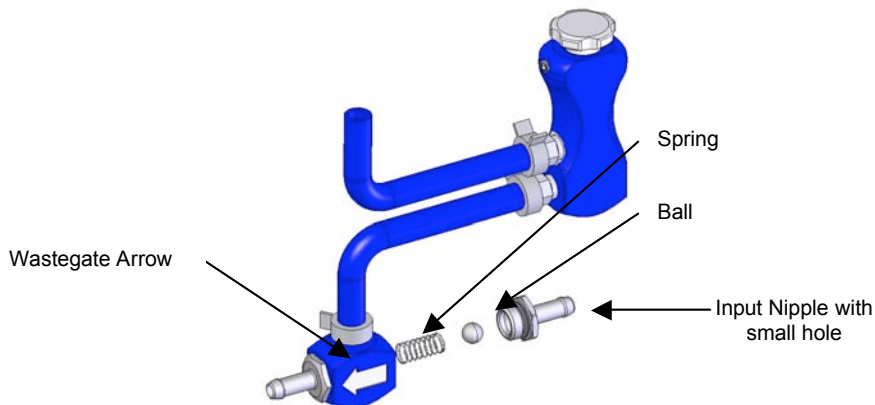

## TRUBLE SHOOTING

The following points should be checked if you find that your engine is developing excessive boost, the boost pressure is fluctuating or the desired boost level cannot be achieved. Please note the following checks will cure 99% of problems experienced when fitting a Turbosmart boost controller.

- Check that the boost controller is installed so that the arrow points toward the wastegate actuator
- Check the joining hoses for splits, cracks or loose connection and are the correct size for the application
- Check to see if the boost controller is blocked or contaminated with dirt or debris
- Ensure that there is nothing but the boost controller in the hose between the pressure source and the wastegate actuator, ie tee pieces for boost gauge or to factory boost solenoid.
- Pressure test the wastegate actuator for leakage, the diaphragm or housing may be cracked or split
- Check that the wastegate is operating correctly

# The Turbosmart Pledge

## TURBOSMART ONE YEAR LIMITED WARRANTY

Turbosmart is a company built on Customer Satisfaction and Service. That is why all of our products go through regimented test procedures before they are packaged and shipped. Turbosmart stands behind its products for one full year after purchase. Terms of Warranty, Service and Returns are as follows:

**Limited Warranty:** Turbosmart warrants its products to be free from defects in material and workmanship under normal use and if properly installed for a period of one year from date of purchase. If found to be defective, it will be replaced or repaired if returned prepaid along with proof of date of purchase. This shall constitute the sole remedy of the purchaser and the sole liability of Turbosmart to the extent permitted by law, the foregoing is exclusive and in lieu of all other warranties or representations whether expressed or implied, including any implied warranty of merchantability or fitness. In no event shall Turbosmart be liable for special or consequential damages. This warranty is only valid on products purchased from Turbosmart Authorized Dealers.

**Service:** After the warranty period has expired, repair service is charged based on a minimum and maximum charge rate. (Contact Customer Service for current rate).

**Returns:** When returning a Turbosmart product for repair, it must be accompanied by a completed Customer Warranty Form and RMA number. To access this form please go to our website [www.turbosmartonline.com](http://www.turbosmartonline.com) and you will find it on the Downloads page.

### THE TURBOSMART PLEDGE

DO NOT USE ANY TURBOSMART PRODUCT UNTIL YOU HAVE CAREFULLY READ AND UNDERSTOOD THE FOLLOWING AGREEMENT.

Please call if you have any questions or do not understand this agreement. Refer to our brochure, website or catalogue for terms and conditions and further information regarding your product. Turbosmart appreciates your business and pride ourselves on our customer service. We are always happy to offer you advice and will provide you with help in any way we can. The purpose of this agreement is to avoid any problems or hard feelings.

We sometimes make mistakes, as do our dealers, distributors and suppliers. Even customers can sometimes order the wrong parts. Do not use, modify, install, trial assemble, nick, drop, scratch or adjust any part until you first check for any damage. Damage must be reported immediately. NO EXCEPTIONS. If there are any components missing please contact your authorized reseller immediately upon receipt of your shipment. Missing components must be reported within five (5) business days of receipt. Parts returned for any reason MUST BE IN RESALABLE CONDITION. It is YOUR responsibility, "THE CUSTOMER" to carefully package any returns to avoid shipping damage. Insurance is highly recommended. Credit cannot be issued for damaged goods.

Turbosmart warrants the quality of the products it designs and manufactures to be free of defects in material and workmanship. This limited warranty is extended only to the original purchaser and may not be transferred or assigned. This limited warranty applies to any product, which after careful inspection by Turbosmart, after receipt of the product from our authorized reseller, is found to have a defect in either material or workmanship. Any modifications to the product will void any and all warranties and will not be exchanged. Before installation, check new car warranty. Turbosmart is not responsible for voiding any original manufactures warranty.

All warranty claims must be returned to the nearest Turbosmart Office, you must return the product and sales receipt, at your own expense, accompanied by the Customer Warranty Form stating the reason for the claim. Proof of purchase must be provided with any warranty claim and will be verified with the authorized reseller from which the product was purchased.

If all the above procedures are followed, and the product is found to be defective in either workmanship or material, Turbosmart shall either repair or replace the product, at its sole discretion, and sole cost. This limited warranty does not cover or apply to any personal injury, labor charges or any other incidental costs or damages caused by the defective product. The individual purchaser acknowledges and agrees that the disclaimer of any liability for personal injury is a material term for this agreement and the individual purchaser agrees to indemnify Turbosmart and to hold Turbosmart harmless for any claim related to the item of the equipment purchased. Under no circumstances will Turbosmart be liable for any damages or expenses by reason of use or sale of any such equipment.

THIS LIMITED WARRANTY IS THE ONLY EXPRESS WARRANTY, WHICH APPLIES TO TURBOSMART PRODUCT AS EXPRESSLY GIVEN IN LIEU OF ANY OTHER WARRANTY EXPRESSED OR IMPLIED, INCLUDING THAT OF MERCHANTABILITY. ANY IMPLIED WARRANTY INCLUDING THAT OF MERCHANTABILITY AND/OR FITNESS FOR A PARTICULAR PURPOSE IS HEREBY LIMITED BY THE SAME TERMS AND TIME LIMITATIONS SET FORTH IN THIS LIMITED EXPRESS WARRANTY AND OTHERWISE EXCLUDED. EXCEPT FOR THOSE OBLIGATIONS ASSUMED HEREIN, TURBOSMART ASSUMES NO OTHER OBLIGATIONS IN CONNECTION WITH THE SALE OF ITS PRODUCTS.

IN THE EVENT THAT THE INDIVIDUAL PURCHASER DOES NOT AGREE WITH THIS AGREEMENT THE BUYER MAY PROMPTLY RETURN THIS PRODUCT, IN A NEW AND UN-USED CONDITION, WITH A DATED PROOF OF PURCHASE, TO THE PLACE OF PURCHASE WITHIN SEVEN (7) DAYS FROM THE DATE OF PURCHASE FOR A FULL REFUND. THE INSTALLATION OF THIS PRODUCT INDICATES THAT THE INDIVIDUAL PURCHASER HAS READ AND UNDERSTOOD THIS AGREEMENT AND ACCEPTS ITS TERMS AND CONDITIONS.

**Happy motoring!**  
**The Turbosmart Team.**

**Head Office:** Turbosmart Pty Limited, PO Box 264 Croydon, NSW, 2132 Australia  
**USA Office:** Turbosmart USA, 1185 Park Center Drive, Suite Q, Vista CA 92081 USA

Ph: +61 (2) 9798 2866  
Ph: (760) 727 7610

Fax: +61 (2) 9798 2826  
Fax: (760) 727 7963

Email: [info@turbosmart.com.au](mailto:info@turbosmart.com.au)  
Email: [sales@turbosmartusa.com](mailto:sales@turbosmartusa.com)